

Trolley for IPE profiles

Part No 315.140 E

Motorized trolley for IP and IPE ("double-T") profiles with 100 to 160 mm width. Motor control through DMX, IR remote control, monopole's radio remote control or Positioning Control System.

Optionally, the trolley can be equipped with current collectors and position sensing.

Motor 230 V AC, 50 Hz, approx. 15 VA. Horizontal travelling speed is approx. 120 mm/s. Different gear boxes can be mounted (e.g. 50:1 or 60:1) to adjust speed to local requirements. Force transmission to the profile is by means of a friction wheel with adjustable contact pressure. The wheels are vulcanized with a special rubber blend that assures very low noise and high durability.

Either side panel may be folded away completely; thus the trolley can be mounted on any position of the rail easily.

Monopoles and motorized pantographs made by MTS already provide mounting points for this trolley. Heavy-duty versions with payloads of up to 250 kg (for e.g. chain hoists) are available.

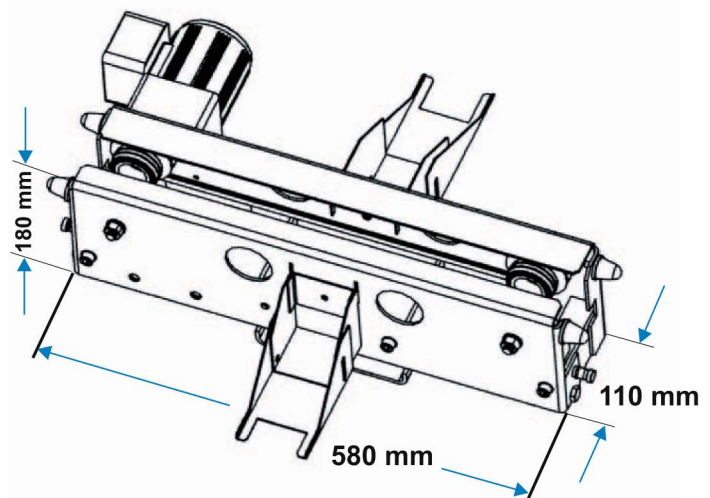

Max. payload 120 kg

Motorized pantograph with IP profile trolley

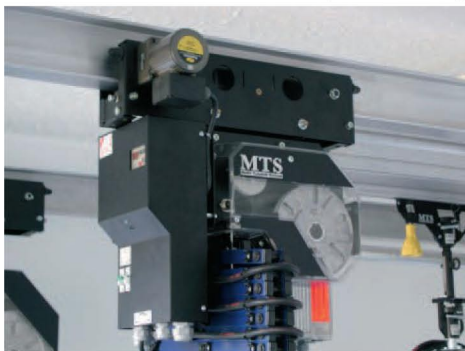

Folding side panels

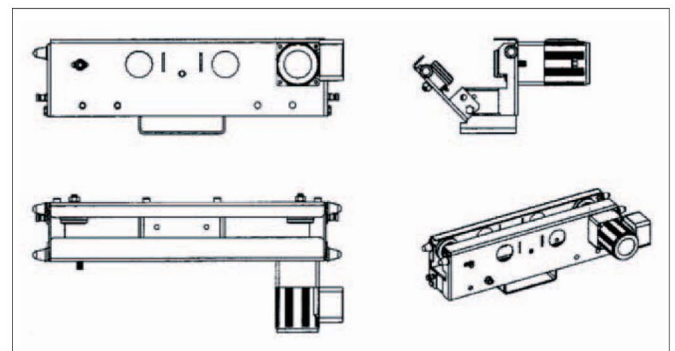

Subject to change without prior notice